

MEMO

TO: Mayor Kesselus & City Council Members

FROM: Michael H. Talbot, City Manager

DATE: March 8, 2016

RE: City Manager's Informational Update Report for the March 8, 2016
City Council Meeting

I. Meetings and Events

A. N/A

II. Update on City Projects and Issues:

A. Discussion and Review of Water Usage for the Period of February 22, 2016 through March 6, 2016: Attached for the City Council's review, as "**Exhibit A**," is the summary of the daily water consumption by the citizens and the businesses of the City of Bastrop for the period of February 22, 2016 through March 6, 2016.

B. Update on the Improvements to the Fire Department Building on Chestnut Street: This item is on the City Council agenda for March 8, 2016 for Council to take action on this matter. As stated in the staff write-up, the overall cost for this project is over the amount that was originally projected and budgeted for this project. Now that that City has a full time "Fire Chief" on staff, the Fire Chief identified some additional worked that he believed should be considered while we were in the process of replacing the façade on the building. The additional work will include items that will provide constant security for the building during the construction, some additional structural materials through-out the building, new insulation in portions of the building and some additional upgraded electrical work. Replacement of the broken brick on the "Planters" and "Heroic Fire Fighter Statue" will also be replaced, as well. "**Exhibit B**" illustrates the façade improvements that will be made to the building. If the Council approves this agenda item Tuesday evening, when it comes before the Council for discussion and action, then I will sign the contracts on Wednesday, and the contractor will commence working on the building in approximately one (1) week to 10 days. Total construction time for this for this project is approximately thirty (30) to forty-five (45) days. The one thing that could delay construction in the next 30 to 45 days would be if we experienced bad weather conditions. Then, obviously, the construction period would be extended as well.

C. Discussion - Review of the Color for the Bus Shelter: The bus shelter is in the process of being fabricated and the last item that needs to be addressed regarding this structure is making the final selection on the color for the "Bus Shelter". Attached as "**Exhibit C**" is a "color chart"

with shows the various colors that the Council may consider and choose from for the "Bus Shelter." Please be prepared to select a color so that I may tell the manufacture how to proceed.

D. Review and Discussion of the Proposed Cost for the Infrastructure Improvements for "Alley D." In working with Mr. Gene Kruppa of BEFCO Engineering, the following cost estimate has been developed for Alley "D":

1. Demolition work of existing paving & Related Items:	\$20,000.00
2. New Base Material for the Parking Lot:	\$38,000.00
3. New Concrete Paving for the Parking Lot:	\$266,000.00
4. New Concrete Curbing:	\$24,700.00
5. New Storm Sewer Improvements:	\$45,000.00
6. Drainage Inlets & Junction Boxes for the Storm Sewer:	\$30,000.00
7. Replacement of the Existing Sewer Mains:	\$60,200.00
8. Relocate Existing Water Meter	\$500.00
9. Upgrades & Improvements to the Primary & Secondary Electrical System:	\$100,000.00
	Sub-Total
	\$584,000.00
10. Engineering & Surveying:	\$51,600.00
11. Contingency 10%	\$58,000.00
	Total:
	<u>\$694,000.00</u>
12. Current Bond Available for Alley "D" Improvements:	<u>[\$242,590.00]</u>
Deficit:	<u>[\$451,141.00]</u>

I will review the above figures with the City Council Tuesday evening. Attached as "Exhibit D" is an overview of the "Preliminary Concept" as to how Alley D would look based upon the improvements noted above.

E. Update on Filling the Vacancy of the Main Street Director's Position: There have been two (2) interviews with the top two (2) candidates to fill the position of Main Street Director over the past two (2) weeks. All of the background checks have been completed on both of the top two (2) candidates. I will be making my decision on the City's new Main Street Director's position the week of March 7, 2016 and will then introduce the selected individual to the Council and public at that time.

F. Update on the Texas Department of Transportation "Tahitian Village" Overpass Project: Since my last update on this project, Hunter Industries, the contractor responsible for the project, has completed the work needed to construct the overpass' retaining walls, bridge supports, and bridge beams. They have also coordinated with the Bastrop Arts in Public Places Commission regarding the overpass murals. Regarding current traffic movements, the contractor has completed the paving, striping, and signal timing work described in my previous update, which appears to have dramatically improved the flow of traffic through the work area. Overall, the project is over 75% complete and is currently well ahead of schedule. In the coming weeks, the contractor will continue installing the retaining wall railings, bridge deck panels, and preparing the overpass subgrade. The contractor is scheduled to pour the bridge driving surface pavement between the end of March and the last half of April.

G. **Review and Discussion Regarding Priorities for the City Manager:** Attached as "**Exhibit E**" is a list of "Projects and Programs" currently underway or planned that I provided to the City Council at the February 21st City Council meeting. I may have inadvertently overlooked some "Projects" or "Programs," so if you recognize one or more that should be included, please feel free to add them to the attached list. I have provided you a spot to assign a "numerical value" to each project or program which will indicate for me the priority you place on each project/program. You have a **total of 100 points to allocate amongst the various Programs and Projects listed.** Once you have completed allocating your 100 points, please return these work sheets to Ms. Traci Chavez and I will develop a "Summary Sheet" showing how the entire Council allocated their 100 points. WE will then discuss the priorities and how we will move forward to accomplish the noted projects and programs as we go forward.

H. **Update on the Water Filtration Project at the Willow-Well Field at Fisherman's Park:** The Willow Well Field filtration project is complete and the Filtration Units were brought online February 23, 2016. The turbidity of the water is being monitored 24 hours a day, in 15 minute intervals. The proper filtration is in place, and now the plant can remove microorganisms that are chlorine resistant, such as giardia, and cryptosporidium. The completion of this project brings the water system into compliance with the state requirement. The improvements should also assist with improving the water quality buy filtering non-soluble minerals and sands.

I. **Update on the Status of the XS Ranch PID:** The major focus of the work on the XS Ranch over the past few weeks has been working on the elements that go into the "Financing Agreement" that will be the document that will set forth details related to the issuance of the "Public Improvement District –Bonds". These documents will ultimately have to be approved by the Texas Attorney General, so it is critical that the City's Bond Council, Bart Fowler, and the City's public financing expert, Dan Wegmiller, are comfortable and on board with the documents being proposed by the XSPID team. JC Brown and Shan Rutherford, as well as Traci Waldron and Wes Brandon and myself participate weekly in conference calls and meetings with the XS PID team members to address questions about the various documents and work being done on them. The City relies heavily on Fowler and Wegmiller with regards to these documents so that once the PID is ready for the sale of Bonds, we can have comfort that the documentation is in place to support that sale.

J. **Update on Zika Virus:** As I am sure the Council is aware, the State of Texas has identified fourteen (14) Zika virus cases, to date. Fortunately, as of today, these cases are all directly or indirectly been related to travel areas of the world where spread of the virus is active and ongoing. While no evidence of local transmissions currently exists in Texas, the "Texas Department of Health" (TDH) has notified local municipal officials that it is highly likely Texas will experience local transmission of the Zika virus by mosquitoes at some point in time. Based upon this notification by the Texas Department of Health the City Staff and I will be developing a "Plan of Action" to address the potential threat of local transmission of Zika virus. This plan of action will include the following measures:

- Initiate or enhance monitoring and surveillance of mosquito activity.
- Accelerate mosquito abatement efforts.
- Develop a local contingency plan for mosquito abatement and surveillance; plan for additional control measures if needed.
- Implement efforts to clean up illegal dump sites and collect heavy trash.

- Encourage citizens to report illegal dumpsites and standing water, and respond quickly to these complaints
- Keep public drains and ditches clear of weeds and trash so water will not collect.
- Conduct neighborhood outreach about precautions individuals can take to protect themselves and their families from mosquito.

The success of this program will depend in large part upon the public's willingness to cooperate and comply with the various voluntary measures to eradicate the mosquito population locally. So, public education and awareness will be an important key. We may try to get a video for our Public TV Channel, as well

K. Update and Discussion on Holding a Bond Election in November 2016: If the City Council wishes to hold a "General Bond Election" in November 2016, I would like to suggest that we hold a "Special Workshop" on this topic either **March 15th**, or **March 29th**, 2016. It is simply not too early to begin planning. The purpose of this workshop is for the Council to identify and clarify the types of projects you would like to consider placing on the November ballot for voter consideration. Once you have identified the projects for the voters to consider, then I will develop a formal 'cost estimate' for each of the projects identified by the City Council and development a summary report of all the projects being considered by the Council. It will take some time to develop the cost estimate for each project, summarize the projects and the present the Council with the amount of all of the projects.

As is the situation in most communities, the Council will generally start out with a large dollar amount and commence the process to determine which projects are most "critical" for the city, and begin to whittle it down a bit, keeping taxes and costs in mind. Then, once the Council is confident that it has identified critical needs, the Council will want to undertake a public information program so that it provides the public with full information on the pros and cons of all of the projects that it is asking the taxpayers to consider for bonds, during the November election. All of this takes time and – as a reminded - the Council must call the November bond election by no later than August 22, 2016.

M. Management/Administrative Activities: Other managerial activities that I undertook over the past two weeks included: attended two (2) litigation meditation Session, attended District Court hearings on the City's pending groundwater permit, attended three (3) HOA meetings for Pine Forrest Unit #6, reviewed and evaluated the City's FY-15 "Annual Audit", spent numerous hours working on the proposed YMCA project, worked in conjunction with the City Attorney on the "Amended Bastrop Marketing Corporation Contract", worked on Human Resources matters and worked on the provision of wastewater services to the "West Bastrop Village Municipal Utility District."

Informational Items Only Not for Discussion or Action:

- **Update on the City of Bastrop's Comprehensive Plan:** The consultant team has completed edits of Chapters 1 through 4 of the Bastrop Comprehensive Plan Update and is providing them to staff for distribution to the Comprehensive Plan Steering Committee (CPSC). Work on Chapter 5, Land Use and Urban Design, and Chapter 6, Transportation, has commenced. The new public engagement is available on *mySidewalk* to consider land use, urban design, and transportation. The next CPSC meeting will be scheduled

for mid-March during which time the committee will review Plan recommendations related to public facilities, housing, and neighborhoods. City staff and the consultant team are preparing revisions to the project schedule to extend periods designated to the review and revision of interim deliverables.

- **Administrative Hearing on Bastrop's Water Permit:** The City's Water Well Permit for Well No. 1 is set to begin on March 23 – 25, at the SOAH Hearing Offices in Austin. There were no spaces available in Bastrop to hold this rescheduled hearing on these dates, so the hearing will be held at the SOAH Hearing Offices on 15th Street, in Austin. The District Court in Bastrop found in favor of the City of Bastrop and the Lost Pines General Manager on their Pleas to the Jurisdiction, this past week, which cleared another procedural hurdle raised by the protestants
-

III. Other City Activities:

A. City of Bastrop Convention Center Activities:

- **Events:**
 - Feb 23 - Ballrooms A and B - Corporate Training
 - Feb 26, 27 and 28 - Entire Facility - City Wide Garage Sale Tradeshow
 - March 1 - Meetings Room 1 & 2 - Plateau Land Management Training
 - March 2 - Meeting Rooms 1 & 2 - Tilson Homes Corporate Training
 - March 3 - Entire Facility Farm Street Opry
 - March 6 - Entire Facility: Bastrop Pregnancy Center Civic Fundraiser
- **Marketing:**
 - The Director continued with marketing and PR efforts for the Center. This included marketing to brides, meeting planners and the March Opry.
 - The Director met with Mayor Kesselus, Becki Womble, Georgina Ngozi, and Nancy Wood to discuss marketing literature and gift bags for groups.
- **Operations:**
 - The staff assisted with walk-in tours and appointments with current clients and potential clients. Layout changes, security requirements, event details and administrative issues were addressed.
 - The Director attended the MPI-THCC – Meeting Professional International Texas Hill Country Chapter Education Session and monthly Board Meeting.
 - Steve Ballard is working on the AC unit in the Main Street office.
 - EventPro software training has been scheduled for the week of March 14 – 18.
- **New Inquiries – (Walk-in included)**
 - Corporate – April 2016, return client, booked
 - Civic – August, shopping area, packet given
 - Conference – Sept. 2016, return client, booked
 - Wedding – May 2016, appt made for tour of facility
 - Civic - Nov 2016 –gave a proposal

New

Inquiries – (Walk-in included) cont.

- Civic - Baby Shower
- Civic – Nov 2016 - Paperwork Pending
- **Booked Events:** Corporate, Wedding, Trade Show, Civic, Seminar/Conference)
 - Corporate – March 2016 30ppl
 - Corporate - April 1 2016
- **Other:**
 - BAIPP, March 19, 2016
 - Bastrop PD Banquet May 12, 2016
 - TML Budget Workshop, June 2016
 - MPI-THCC Annual Award Banquet – June 24, 2016
 - Chamber 1st Responder Luncheon – October 5 2016
- **Upcoming Events:** March/April 2016
 - Civic – March 5, 2016
 - Seminar – March 12, 2016
 - Civic – March 19, 2016
 - Civic – March 23, 2016
 - Wedding – March 26, 2016
 - Corporate – April 1, 2016
 - Farm Street Opry – April 7, 2016
 - Civic - April 9, 2016
 - Wedding -April 16, 2016
 - Civic - April 23, 2016
 - Corporate – April 26, 2016
 - Conference - April 30, 2016

B. The City of Bastrop’s Main Street Program:

- **Business Update**
 - Rising Phoenix Adventures has moved into the BMSP area. They are now in the 1400 block of Chestnut Street across from the Convention Center.
 - A new business, Van Gogh & Paint, has opened in the old Jung home at Pecan and Chestnut Streets. They offer public classes in painting and private parties with painting activities.
 - Blwr Myles (on Pine Street) has closed.
- **Committee/Board Updates**
 - On 2/24 the Organization Committee met and priorities identified were plans for a Volunteer Appreciation event in the summer and the update on establishing a 501(c) 3 to raise funds for projects.
 - On 3/1 the Promotions Committee met and priorities identified include updates for the app and making it more functional, and establishing a Bingo card for teachers which would bring them downtown to shop and eat.
- **Partnerships**

- Interim Director attended DBA's February Board meeting on February 24. The group worked through issues related to support for downtown businesses.
- **Main Street Program activities**
 - The tourism smart phone app, Bastrop TX, has been overhauled extensively and made more functional.
 - Website in partnership with DBA is being upgraded and for the next few months will feature a blog showcasing rehabilitation projects which have happened in the last 8 years downtown. The first blog features R A Green Mercantile and is on the website now.
 - Interim Director and a BMSP Board member presented a class on Building Entrepreneur Communities to second year students at the Community Development Institute on February 29. The Institute is offered annually through Lone Star College in The Woodlands, TX.

C. The Planning and Development Department:

Inspections Bi-Weekly Construction Report – March 4, 2016
For March 8, 2016 City Council Meeting

- Air Quality is measured from August to November. No additional Air Quality data from McKinney Roughs Monitoring Site is available.
- Tuesday, March 8th – 6:30 pm - City Council Meeting
- **Consent Agenda:**
- Final Plat for Allen Subdivision – 1 mile ETJ
- Statutory denial of Hill Subdivision located within Area A of Bastrop's ETJ
- Wednesday, March 9th – 6:00 pm - BOA Meeting
- 103 Hawea Court – interior side setback
- 704 Magnolia – variance to lot size (Magnolia Gardens)
- Form Based Code "North Area" public meeting scheduled for Thursday, March 24, 2016 @6PM. All citizens invited to attend.
- Major Construction Projects in process:
 - Goodwill Store – walls up; project approximately 25% complete
 - Lost Pines Art Guild – site work approximately 15% complete
 - Mama Fu's – project approximately 30 % complete
 - Sally's Beauty Supply – CO issued 2/29/16
 - Western Liquor Beverage – CO issued 2/29/16
 - Elysian Nail Salon – project approximately 10% complete
 - Coghlan Group – site work 89% complete; project approximately 90% complete
 - Garcia's Restaurant – project approximately 45% complete
 - Elliott Electric – site work approximately 15% complete
 - Pecan Park Residential – 3 houses permitted

C. Update on the YMCA Program:

Membership

- Membership 216 Units
 - 626 Individuals

Administrative

- Number Served in February
 - Health & Wellness - 709
 - Child Watch - 148
 - Youth & Family -410
 - Sports – 89
 - Total served in February 1356
- Annual Campaign continues. We are currently at 48% of goal
- Held New Hire Orientation for the association for the first time at the Bastrop location.
- Hired new welcome team/child watch team member
- Hired Pool Manager

Y Activities Report:

Program Monthly Update:

- JYG State Conference was a Feb 25-27 with 600 students from the state of TX in attendance.
- The Bastrop Y track team participated in the Austin joint meet.
- Gymnastics class was filled to capacity again.
- Kickboxing has been moved to a larger location to accommodate the adult and child participation.
- Registration continues for Youth Soccer, Youth Girls Volleyball and Adult Volleyball
- For spring break, a Mini Art Camp and a Cheer Camp have been added.
- Little and Junior Chef Program begins in March.

Dates to remember:

- Funday Friday is *March 4th* from 11am to 5pm with cycling, smoothies, herbs and Happy Hour Yoga. See flyer attached.
- Community Garden work day is scheduled for *March 12th*.
- Easter Egg Hunt is scheduled for *March 19th*.
- Healthy Kids Day is scheduled for *April 2nd*.

Inviting input from the City Council related to issues for possible inclusion on future agendas related to issues such as (but not limited to) municipal projects, personnel, public property, development and other City/public business.

EXHIBIT A
WATER USAGE FOR THE PERIOD
February 22, through March 6, 2016

**WATER WORKS OPERATIONS FOR GROUND WATER SUPPLIES
CITY OF BASTROP, BASTROP COUNTY, TEXAS**

WATER SYSTEM I. D. #: 0110001

Month of: _____

Mar-16

Date	Raw water from wells										Pumped from high service pumps					Mar-16		
	C	F	C&F	G	D&E	G D&E	H raw	I	total MGD	Zone 1	Zone 2	Zone 3	MGD	WellPump	Percent	Z1	Z2	Z3
1	93	214	307	481	262	743	0	0	1,050	323	766	0	1,109	-0.059	0.29	0.71	0.00	
2	115	257	372	499	283	762	0	0	1,154	374	827	0	1,201	-0.047	0.31	0.69	0.00	
3	114	253	367	440	291	731	0	0	1,098	367	779	0	1,146	-0.048	0.32	0.68	0.00	
4	115	253	368	499	324	823	0	0	1,191	350	879	0	1,229	-0.038	0.28	0.72	0.00	
5	115	256	371	524	336	860	0	0	1,231	375	913	0	1,288	-0.057	0.29	0.71	0.00	
6	110	246	356	499	317	816	0	0	1,172	367	900	0	1,267	-0.095	0.29	0.71	0.00	
7																		
8																		
9																		
10																		
11																		
12																		
13																		
14																		
15																		
16																		
17																		
18																		
19																		
20																		
21																		
22																		
23																		
24																		
25																		
26																		
27																		
28																		
29																		
30																		
31																		
Total	662	1,479	2,141	2,942	1,813	4,755	-	-	6,896	2,156	5,084	-	7,240	-0.344				
Average	110	247	357	490	302	793	-	-	1,149	359	847	-	1,207	-0.057	0.30	0.70	-	
Maxim	115	257	372	524	336	860	-	-	1,231	375	913	-	1,288	-0.038	0.32	0.72	-	
Minim	93	214	307	440	262	731	-	-	1,050	323	779	-	1,109	-0.095	0.28	0.68	-	

**WATER WORKS OPERATIONS FOR GROUND WATER SUPPLIES
CITY OF BASTROP, BASTROP COUNTY, TEXAS**

WATER SYSTEM I. D. #: 0110001

Month of: Feb-16

Date	Raw water from wells										Pumped from high service pumps			Feb-16			
	C	F	C&F	G	D&E	G D&E	H raw	I	total MGD	Zone 1	Zone 2	Zone 3	MGD	Well/Pump	Percent Z 1	Z 2	Z 3
1	82	257	339	150	96	246	241	247	1,073	318	294	485	1,097	-0.024	0.29	0.27	0.44
2	97	308	405	196	129	325	228	234	1,192	219	540	460	1,219	-0.027	0.18	0.44	0.38
3	67	206	273	125	76	201	315	323	1,112	161	302	590	1,053	0.059	0.15	0.29	0.56
4	99	320	419	139	85	224	234	240	1,117	321	244	453	1,018	0.099	0.32	0.24	0.44
5	127	404	531	258	155	413	45	48	1,037	431	579	81	1,091	-0.054	0.40	0.53	0.07
6	136	431	567	272	168	440	0	0	1,007	418	652	0	1,070	-0.063	0.39	0.61	0.00
7	144	456	600	288	179	467	0	0	1,067	436	682	0	1,118	-0.051	0.39	0.61	0.00
8	141	450	591	220	133	353	0	0	0,944	457	529	0	0,986	-0.042	0.46	0.54	0.00
9	142	452	594	274	169	443	0	0	1,037	410	649	0	1,059	-0.022	0.39	0.61	0.00
10	151	482	633	290	171	461	0	0	1,094	454	711	0	1,165	-0.071	0.39	0.61	0.00
11	145	465	610	273	170	443	0	0	1,053	441	696	0	1,137	-0.084	0.39	0.61	0.00
12	148	473	621	299	169	468	0	0	1,089	442	732	0	1,174	-0.085	0.38	0.62	0.00
13	151	488	639	310	183	493	0	0	1,132	447	722	0	1,169	-0.037	0.38	0.62	0.00
14	157	504	661	319	185	504	0	0	1,165	440	720	0	1,160	0.005	0.38	0.62	0.00
15	154	490	644	310	175	485	0	0	1,129	450	775	0	1,225	-0.096	0.37	0.63	0.00
16	140	455	595	299	179	478	0	0	1,073	456	722	0	1,180	-0.107	0.39	0.61	0.00
17	161	520	681	300	182	482	0	0	1,163	427	794	0	1,221	-0.058	0.35	0.65	0.00
18	156	502	658	251	151	402	0	0	1,060	444	676	0	1,120	-0.060	0.40	0.60	0.00
19	159	513	672	325	189	514	0	0	1,186	438	798	0	1,236	-0.050	0.35	0.65	0.00
20	152	533	685	331	188	519	0	0	1,204	422	864	0	1,286	-0.082	0.33	0.67	0.00
21	184	556	740	359	195	554	0	0	1,294	410	912	0	1,322	-0.028	0.31	0.69	0.00
22	160	519	679	329	187	516	0	0	1,195	406	831	0	1,237	-0.042	0.33	0.67	0.00
23	125	407	532	259	149	408	0	0	0,940	188	804	0	0,992	-0.052	0.19	0.81	0.00
24	145	468	613	296	167	463	0	0	1,076	278	808	0	1,086	-0.010	0.26	0.74	0.00
25	150	493	643	314	178	492	0	0	1,135	323	849	0	1,172	-0.037	0.28	0.72	0.00
26	144	465	609	294	171	465	0	0	1,074	331	748	0	1,079	-0.005	0.31	0.69	0.00
27	127	410	537	277	164	441	0	0	0,978	346	717	0	1,063	-0.085	0.33	0.67	0.00
28	136	434	570	276	159	435	0	0	1,005	337	693	0	1,030	-0.025	0.33	0.67	0.00
29	141	458	599	290	159	449	0	0	1,048	346	765	0	1,111	-0.063	0.31	0.69	0.00
30																	
31																	
Total	4,021	12,919	16,940	7,923	4,661	12,584	1,063	1,092	31,679	10,999	19,808	2,069	32,876	-1.197			
Aver	139	445	584	273	161	434	37	38	1,092	379	663	71	1,134	-0.041	0.33	0.60	0.07
Max	184	556	740	359	195	554	315	323	1,294	458	912	590	1,322	0.099	0.46	0.81	0.56
Min	67	206	273	125	76	201	-	-	0,940	161	244	-	0,986	-0.107	0.15	0.24	-

EXHIBIT B
Fire Station Drawings

City of Bastrop Fire Station Facade Renovation - Construction Documents

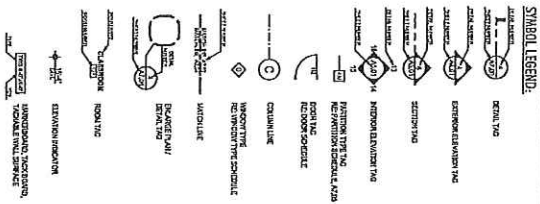

PROJECT LOCATION:
BASTROP FIRE DEPARTMENT
800 CHINA MOUNTAIN
BASTROP, TEXAS

PROJECT IMAGES:

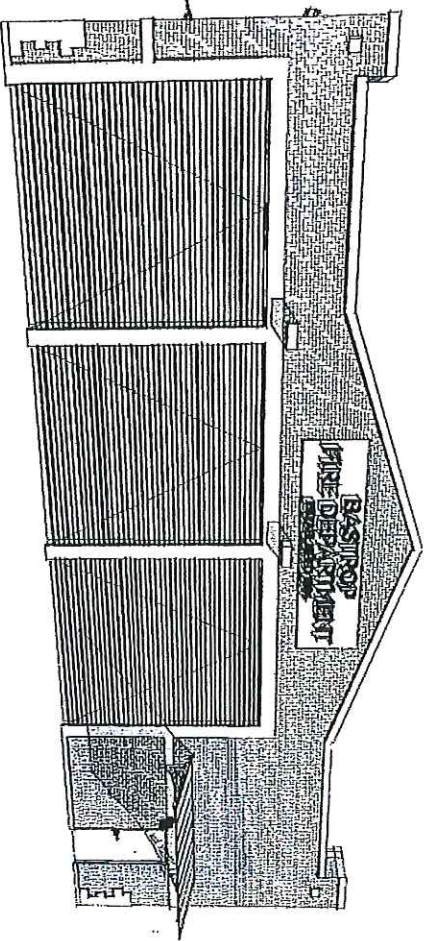

- PROJECT NOTES:**
1. CONSULT WITH ARCHITECT FOR ALL SAFETY PRECAUTIONS TO BE TAKEN DURING CONSTRUCTION.
 2. ALL WORK SHALL BE IN ACCORDANCE WITH THE LATEST EDITIONS OF THE INTERNATIONAL BUILDING CODES AND ALL APPLICABLE LOCAL ORDINANCES.
 3. THE CONTRACTOR SHALL BE RESPONSIBLE FOR OBTAINING ALL NECESSARY PERMITS AND APPROVALS.

SHEET INDEX:

- GENERAL**
- 01.00 GENERAL NOTES
 - 02.00 EXTERIOR FINISHES
 - 03.00 INTERIOR FINISHES
- ARCHITECTURAL**
- 04.00 EXTERIOR ELEVATIONS
 - 05.00 INTERIOR ELEVATIONS
 - 06.00 SECTION ELEVATIONS
 - 07.00 INTERIOR FINISHES
 - 08.00 EXTERIOR FINISHES
 - 09.00 INTERIOR FINISHES
 - 10.00 EXTERIOR FINISHES
 - 11.00 INTERIOR FINISHES
 - 12.00 EXTERIOR FINISHES
 - 13.00 INTERIOR FINISHES
 - 14.00 EXTERIOR FINISHES
 - 15.00 INTERIOR FINISHES
 - 16.00 EXTERIOR FINISHES
 - 17.00 INTERIOR FINISHES
 - 18.00 EXTERIOR FINISHES
 - 19.00 INTERIOR FINISHES
 - 20.00 EXTERIOR FINISHES
 - 21.00 INTERIOR FINISHES
 - 22.00 EXTERIOR FINISHES
 - 23.00 INTERIOR FINISHES
 - 24.00 EXTERIOR FINISHES
 - 25.00 INTERIOR FINISHES
 - 26.00 EXTERIOR FINISHES
 - 27.00 INTERIOR FINISHES
 - 28.00 EXTERIOR FINISHES
 - 29.00 INTERIOR FINISHES
 - 30.00 EXTERIOR FINISHES
 - 31.00 INTERIOR FINISHES
 - 32.00 EXTERIOR FINISHES
 - 33.00 INTERIOR FINISHES
 - 34.00 EXTERIOR FINISHES
 - 35.00 INTERIOR FINISHES
 - 36.00 EXTERIOR FINISHES
 - 37.00 INTERIOR FINISHES
 - 38.00 EXTERIOR FINISHES
 - 39.00 INTERIOR FINISHES
 - 40.00 EXTERIOR FINISHES
 - 41.00 INTERIOR FINISHES
 - 42.00 EXTERIOR FINISHES
 - 43.00 INTERIOR FINISHES
 - 44.00 EXTERIOR FINISHES
 - 45.00 INTERIOR FINISHES
 - 46.00 EXTERIOR FINISHES
 - 47.00 INTERIOR FINISHES
 - 48.00 EXTERIOR FINISHES
 - 49.00 INTERIOR FINISHES
 - 50.00 EXTERIOR FINISHES
 - 51.00 INTERIOR FINISHES
 - 52.00 EXTERIOR FINISHES
 - 53.00 INTERIOR FINISHES
 - 54.00 EXTERIOR FINISHES
 - 55.00 INTERIOR FINISHES
 - 56.00 EXTERIOR FINISHES
 - 57.00 INTERIOR FINISHES
 - 58.00 EXTERIOR FINISHES
 - 59.00 INTERIOR FINISHES
 - 60.00 EXTERIOR FINISHES
 - 61.00 INTERIOR FINISHES
 - 62.00 EXTERIOR FINISHES
 - 63.00 INTERIOR FINISHES
 - 64.00 EXTERIOR FINISHES
 - 65.00 INTERIOR FINISHES
 - 66.00 EXTERIOR FINISHES
 - 67.00 INTERIOR FINISHES
 - 68.00 EXTERIOR FINISHES
 - 69.00 INTERIOR FINISHES
 - 70.00 EXTERIOR FINISHES
 - 71.00 INTERIOR FINISHES
 - 72.00 EXTERIOR FINISHES
 - 73.00 INTERIOR FINISHES
 - 74.00 EXTERIOR FINISHES
 - 75.00 INTERIOR FINISHES
 - 76.00 EXTERIOR FINISHES
 - 77.00 INTERIOR FINISHES
 - 78.00 EXTERIOR FINISHES
 - 79.00 INTERIOR FINISHES
 - 80.00 EXTERIOR FINISHES
 - 81.00 INTERIOR FINISHES
 - 82.00 EXTERIOR FINISHES
 - 83.00 INTERIOR FINISHES
 - 84.00 EXTERIOR FINISHES
 - 85.00 INTERIOR FINISHES
 - 86.00 EXTERIOR FINISHES
 - 87.00 INTERIOR FINISHES
 - 88.00 EXTERIOR FINISHES
 - 89.00 INTERIOR FINISHES
 - 90.00 EXTERIOR FINISHES
 - 91.00 INTERIOR FINISHES
 - 92.00 EXTERIOR FINISHES
 - 93.00 INTERIOR FINISHES
 - 94.00 EXTERIOR FINISHES
 - 95.00 INTERIOR FINISHES
 - 96.00 EXTERIOR FINISHES
 - 97.00 INTERIOR FINISHES
 - 98.00 EXTERIOR FINISHES
 - 99.00 INTERIOR FINISHES
 - 100.00 EXTERIOR FINISHES

Available for download from files.fromberg.com/

OWNER

City of Bastrop
#Client Address1
Bastrop, Texas Client Postcode
#Client Email

ARCHITECT

FROMBERG ASSOCIATES, LTD
2408 Lane Austin Blvd.
Austin, Texas 78703
efromb@fromberg.com

COVER SHEET

Sheet Number:

Model Number: 1509
Date: 03/02/2016
Scale: A0.00

City of Bastrop
Fire Station Facade Renovation
Bastrop, Texas
http://www.cityofbastrop.com/

FROMBERG ASSOCIATES, LTD
21064 Cedar Austin Blvd. • Austin, Texas 78703
Ph (512) 455-8171 • Fax (512) 455-8187
www.fromberg.com

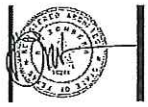

ARCHITECTURAL GENERAL NOTES

- 1. ALL WORK SHALL BE DONE IN ACCORDANCE WITH THE LATEST EDITIONS OF THE BUILDING CODES AND SPECIFICATIONS, AS APPLICABLE, AND THE CITY OF BASTROP SPECIFICATIONS AND STANDARD DRAWINGS, AS APPLICABLE.
2. THE CONTRACTOR SHALL BE RESPONSIBLE FOR OBTAINING ALL NECESSARY PERMITS AND APPROVALS FROM THE CITY OF BASTROP, MISSOURI, AND THE MISSOURI DEPARTMENT OF REVENUE, AS APPLICABLE.
3. THE CONTRACTOR SHALL MAINTAIN ACCESS TO ALL UTILITIES AT ALL TIMES AND SHALL BE RESPONSIBLE FOR PROTECTING ALL UTILITIES FROM DAMAGE.
4. THE CONTRACTOR SHALL BE RESPONSIBLE FOR PROTECTING ALL EXISTING STRUCTURES AND UTILITIES FROM DAMAGE.
5. THE CONTRACTOR SHALL MAINTAIN ACCESS TO ALL UTILITIES AT ALL TIMES AND SHALL BE RESPONSIBLE FOR PROTECTING ALL UTILITIES FROM DAMAGE.

- 1. THE CONTRACTOR SHALL MAINTAIN ACCESS TO ALL UTILITIES AT ALL TIMES AND SHALL BE RESPONSIBLE FOR PROTECTING ALL UTILITIES FROM DAMAGE.
2. THE CONTRACTOR SHALL BE RESPONSIBLE FOR PROTECTING ALL EXISTING STRUCTURES AND UTILITIES FROM DAMAGE.
3. THE CONTRACTOR SHALL MAINTAIN ACCESS TO ALL UTILITIES AT ALL TIMES AND SHALL BE RESPONSIBLE FOR PROTECTING ALL UTILITIES FROM DAMAGE.

- 1. THE CONTRACTOR SHALL MAINTAIN ACCESS TO ALL UTILITIES AT ALL TIMES AND SHALL BE RESPONSIBLE FOR PROTECTING ALL UTILITIES FROM DAMAGE.
2. THE CONTRACTOR SHALL BE RESPONSIBLE FOR PROTECTING ALL EXISTING STRUCTURES AND UTILITIES FROM DAMAGE.
3. THE CONTRACTOR SHALL MAINTAIN ACCESS TO ALL UTILITIES AT ALL TIMES AND SHALL BE RESPONSIBLE FOR PROTECTING ALL UTILITIES FROM DAMAGE.

- 1. THE CONTRACTOR SHALL MAINTAIN ACCESS TO ALL UTILITIES AT ALL TIMES AND SHALL BE RESPONSIBLE FOR PROTECTING ALL UTILITIES FROM DAMAGE.
2. THE CONTRACTOR SHALL BE RESPONSIBLE FOR PROTECTING ALL EXISTING STRUCTURES AND UTILITIES FROM DAMAGE.
3. THE CONTRACTOR SHALL MAINTAIN ACCESS TO ALL UTILITIES AT ALL TIMES AND SHALL BE RESPONSIBLE FOR PROTECTING ALL UTILITIES FROM DAMAGE.

- 1. THE CONTRACTOR SHALL MAINTAIN ACCESS TO ALL UTILITIES AT ALL TIMES AND SHALL BE RESPONSIBLE FOR PROTECTING ALL UTILITIES FROM DAMAGE.
2. THE CONTRACTOR SHALL BE RESPONSIBLE FOR PROTECTING ALL EXISTING STRUCTURES AND UTILITIES FROM DAMAGE.
3. THE CONTRACTOR SHALL MAINTAIN ACCESS TO ALL UTILITIES AT ALL TIMES AND SHALL BE RESPONSIBLE FOR PROTECTING ALL UTILITIES FROM DAMAGE.

DEFINITIONS

- 1. ARCHITECT: THE ARCHITECT SHALL BE RESPONSIBLE FOR THE DESIGN AND CONSTRUCTION OF THE PROJECT.
2. CONTRACTOR: THE CONTRACTOR SHALL BE RESPONSIBLE FOR THE CONSTRUCTION OF THE PROJECT.
3. CITY OF BASTROP: THE CITY OF BASTROP SHALL BE RESPONSIBLE FOR THE PERMITTING AND INSPECTION OF THE PROJECT.

REVISION NOTES

- 1. THE CONTRACTOR SHALL MAINTAIN ACCESS TO ALL UTILITIES AT ALL TIMES AND SHALL BE RESPONSIBLE FOR PROTECTING ALL UTILITIES FROM DAMAGE.
2. THE CONTRACTOR SHALL BE RESPONSIBLE FOR PROTECTING ALL EXISTING STRUCTURES AND UTILITIES FROM DAMAGE.
3. THE CONTRACTOR SHALL MAINTAIN ACCESS TO ALL UTILITIES AT ALL TIMES AND SHALL BE RESPONSIBLE FOR PROTECTING ALL UTILITIES FROM DAMAGE.

REFLECTED CEILING PLAN NOTES

- 1. THE CONTRACTOR SHALL MAINTAIN ACCESS TO ALL UTILITIES AT ALL TIMES AND SHALL BE RESPONSIBLE FOR PROTECTING ALL UTILITIES FROM DAMAGE.
2. THE CONTRACTOR SHALL BE RESPONSIBLE FOR PROTECTING ALL EXISTING STRUCTURES AND UTILITIES FROM DAMAGE.
3. THE CONTRACTOR SHALL MAINTAIN ACCESS TO ALL UTILITIES AT ALL TIMES AND SHALL BE RESPONSIBLE FOR PROTECTING ALL UTILITIES FROM DAMAGE.

INTERIOR ELEVATIONS NOTES

- 1. THE CONTRACTOR SHALL MAINTAIN ACCESS TO ALL UTILITIES AT ALL TIMES AND SHALL BE RESPONSIBLE FOR PROTECTING ALL UTILITIES FROM DAMAGE.
2. THE CONTRACTOR SHALL BE RESPONSIBLE FOR PROTECTING ALL EXISTING STRUCTURES AND UTILITIES FROM DAMAGE.
3. THE CONTRACTOR SHALL MAINTAIN ACCESS TO ALL UTILITIES AT ALL TIMES AND SHALL BE RESPONSIBLE FOR PROTECTING ALL UTILITIES FROM DAMAGE.

MEZZANINE NOTES

- 1. THE CONTRACTOR SHALL MAINTAIN ACCESS TO ALL UTILITIES AT ALL TIMES AND SHALL BE RESPONSIBLE FOR PROTECTING ALL UTILITIES FROM DAMAGE.
2. THE CONTRACTOR SHALL BE RESPONSIBLE FOR PROTECTING ALL EXISTING STRUCTURES AND UTILITIES FROM DAMAGE.
3. THE CONTRACTOR SHALL MAINTAIN ACCESS TO ALL UTILITIES AT ALL TIMES AND SHALL BE RESPONSIBLE FOR PROTECTING ALL UTILITIES FROM DAMAGE.

ROOFING NOTES

- 1. THE CONTRACTOR SHALL MAINTAIN ACCESS TO ALL UTILITIES AT ALL TIMES AND SHALL BE RESPONSIBLE FOR PROTECTING ALL UTILITIES FROM DAMAGE.
2. THE CONTRACTOR SHALL BE RESPONSIBLE FOR PROTECTING ALL EXISTING STRUCTURES AND UTILITIES FROM DAMAGE.
3. THE CONTRACTOR SHALL MAINTAIN ACCESS TO ALL UTILITIES AT ALL TIMES AND SHALL BE RESPONSIBLE FOR PROTECTING ALL UTILITIES FROM DAMAGE.

Architectural drawings showing floor plans, elevations, and sections with dimensions and labels such as 'FLOOR PLAN', 'ELEVATION', and 'SECTION'. Includes a grid system and various annotations.

ARCHITECTURAL GENERAL NOTES
1. ALL WORK SHALL BE DONE IN ACCORDANCE WITH THE LATEST EDITIONS OF THE BUILDING CODES AND SPECIFICATIONS, AS APPLICABLE, AND THE CITY OF BASTROP SPECIFICATIONS AND STANDARD DRAWINGS, AS APPLICABLE.
2. THE CONTRACTOR SHALL BE RESPONSIBLE FOR OBTAINING ALL NECESSARY PERMITS AND APPROVALS FROM THE CITY OF BASTROP, MISSOURI, AND THE MISSOURI DEPARTMENT OF REVENUE, AS APPLICABLE.

City of Bastrop
Fire Station Facade Renovation
Bastrop, Texas
FROMBERG ASSOCIATES, LTD
7100 N. Loop West, Suite 1000, Dallas, Texas 75207
(972) 241-1111
www.fromberg.com

GENERAL NOTES
 REFER TO SHEET 1401 FOR INTERIOR, GENERAL NOTES, CONDITIONS AND ALIAS. SEE SHEET



FROMBERG ASSOCIATES, LTD
 2106 Lake Austin Blvd., Austin, Texas 78701
 PA (512) 455-9171 • Fax (512) 455-1837
 www.fromberg.com

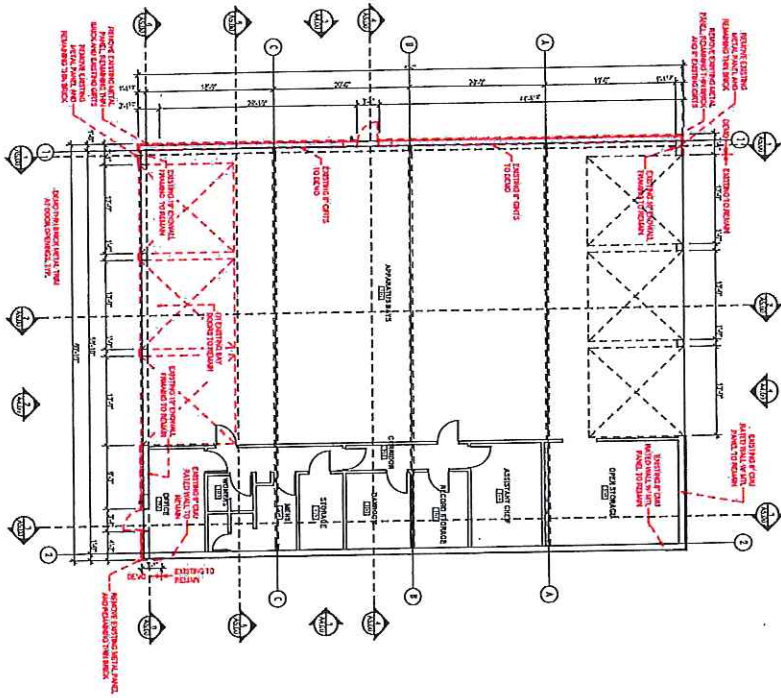

1 DEMOLITION PLAN
 SCALE: 1/8" = 1'-0"

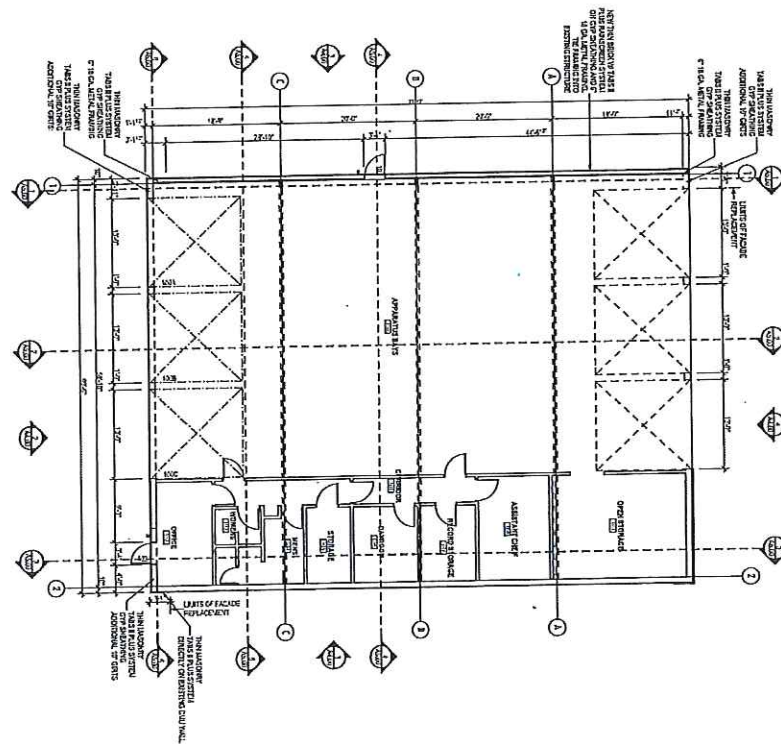

2 RENOVATION PLAN
 SCALE: 1/8" = 1'-0"

DEMOLITION AND RENOVATION PLAN

City of Bastrop
Fire Station Facade Renovation
 Bastrop, Texas

Project Number: 020220716
 Date: 12/09
 Scale: A2.00

GENERAL NOTES
REFER TO SHEET A2.01 FOR ARCHITECTURAL, MECHANICAL, ELECTRICAL, SANITARY/PLUMBING, STRUCTURAL, AND INTERIORS DRAWINGS.



FROMBERG ASSOCIATES, LTD
2106 Lake Austin Blvd., Austin, Texas 78703
Ph (512) 495-5173 • Fax (512) 475-1832
www.fromberg.com

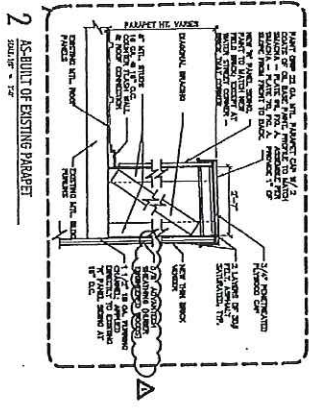
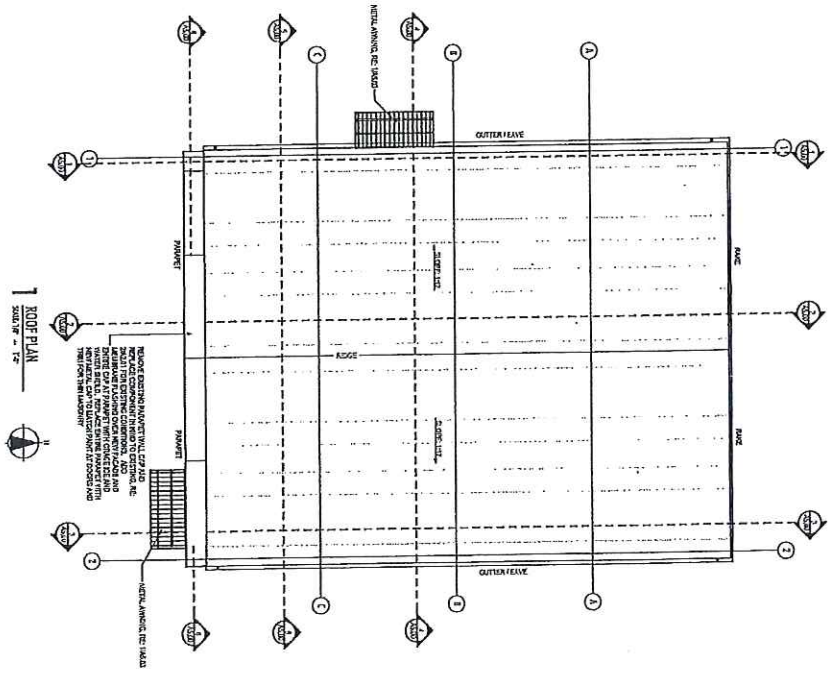

ROOF PLAN

A2.01

Project Name	1509
Date	03/02/2016
Sheet No.	
Scale	
Author	
Checker	
Designer	
Reviewer	
Approver	

City of Bastrop
Fire Station Facade Renovation
Bastrop, Texas

Graphic Design: Fromberg Associates, Ltd. 10/15/2015

GENERAL NOTES
 REFER TO SHEET 141 FOR ARCHITECTURAL SYMBOLS, DETAILS, NOTES, WORKMANSHIP AND LISTED SCHEDULE

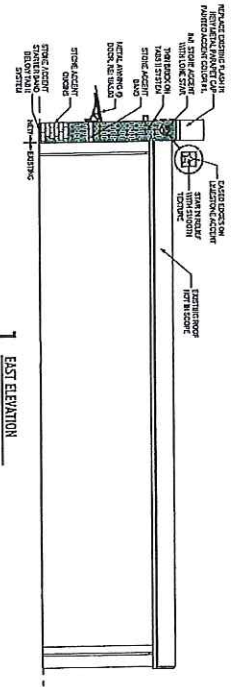

1 EAST ELEVATION
 SCALE: 1/8" = 1'-0"

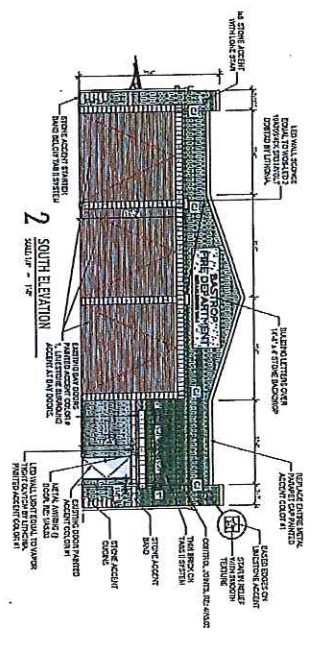

2 SOUTH ELEVATION
 SCALE: 1/8" = 1'-0"

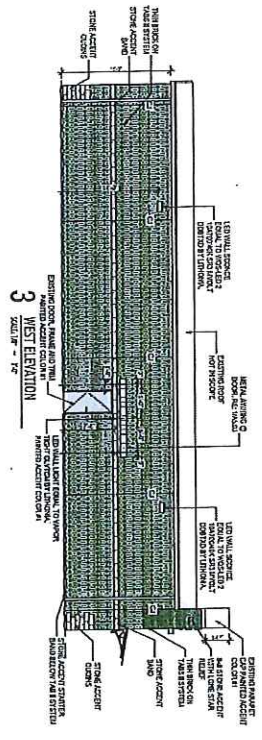

3 WEST ELEVATION
 SCALE: 1/8" = 1'-0"

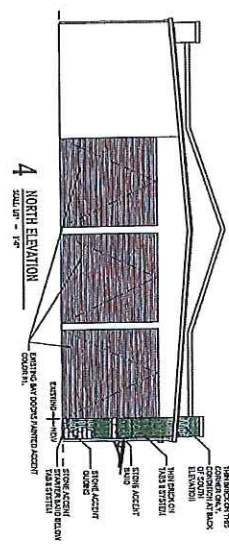

4 NORTH ELEVATION
 SCALE: 1/8" = 1'-0"

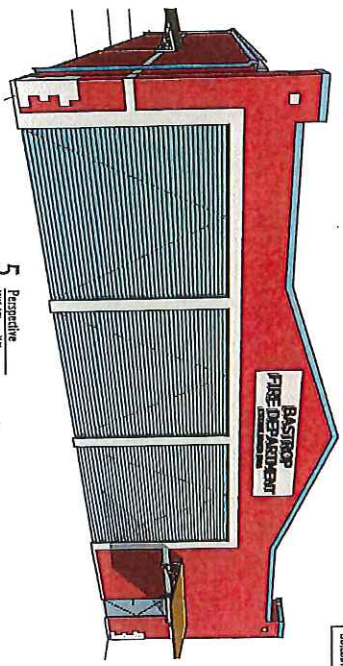

5 Perspective
 SCALE: 1/8" = 1'-0"

EXTERIOR FINISHES:
 THIN BRICK - SILVER BED VELOUR BY ENCOBILT
 STONE - LIGHT STONE BRICK COMPANION BY SIEMEN WILLIAMS
 ANNING ROOF PANEL - MEDIUM PROFILE KRYNAB COPPER BY METAL WARE
 BUILDING LETTERS - MEDIUM BRONZE

ELEVATIONS

Project Number	1508
Project Name	Bastrop Fire Station Facade Renovation
Date	03/02/2016
Scale	A4.00

City of Bastrop
Fire Station Facade Renovation
 Bastrop, Texas



FROMBERG ASSOCIATES, LTD
 2108 Cedar Austin Blvd. • Austin, Texas 78703
 PH (512) 415-5131 • FAX (512) 415-1877
 www.fromberg.com



GENERAL NOTES
 REFER TO SHEET A41 FOR ARCHITECTURAL SYMBOLS, MATERIALS, FINISHES, HEIGHTS & LEVELS, ETC.

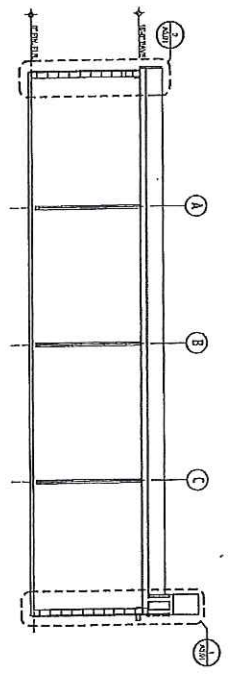

1 BUILDING SECTION
 SCALE = 1/4"

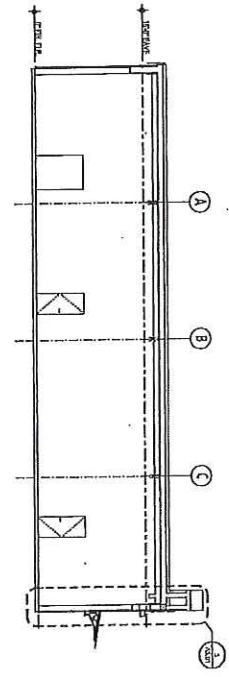

2 BUILDING SECTION
 SCALE = 1/4"

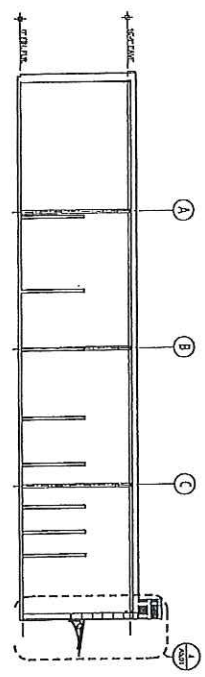

3 BUILDING SECTION
 SCALE = 1/4"

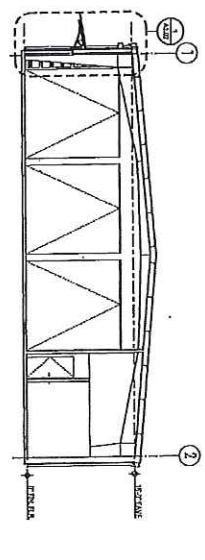

4 BUILDING SECTION
 SCALE = 1/4"

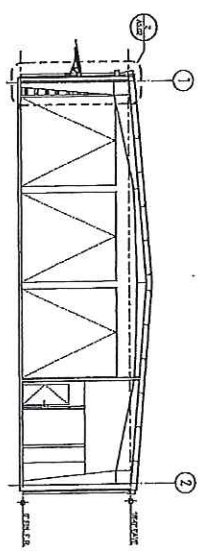

5 BUILDING SECTION
 SCALE = 1/4"

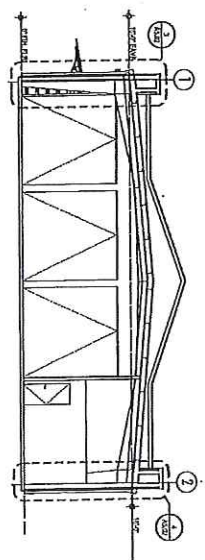

6 BUILDING SECTION
 SCALE = 1/4"

BUILDING SECTIONS

Project Name	City of Bastrop Fire Station Facade Renovation
Site	Bastrop, Texas
Scale	As Shown
Sheet No.	1509
Revision	03/02/2016
Contract No.	A5.00



FROMBERG ASSOCIATES, LTD
 2106 Lake Austin Blvd., Austin, Texas 78703
 P: (512) 455-9100 • F: (512) 455-1877
 www.bzbap.com



1 WALL SECTION
SCALE: 1/4" = 1'-0"

2 WALL SECTION
SCALE: 1/4" = 1'-0"

3 WALL SECTION
SCALE: 1/4" = 1'-0"

4 WALL SECTION
SCALE: 1/4" = 1'-0"

WALL SECTIONS

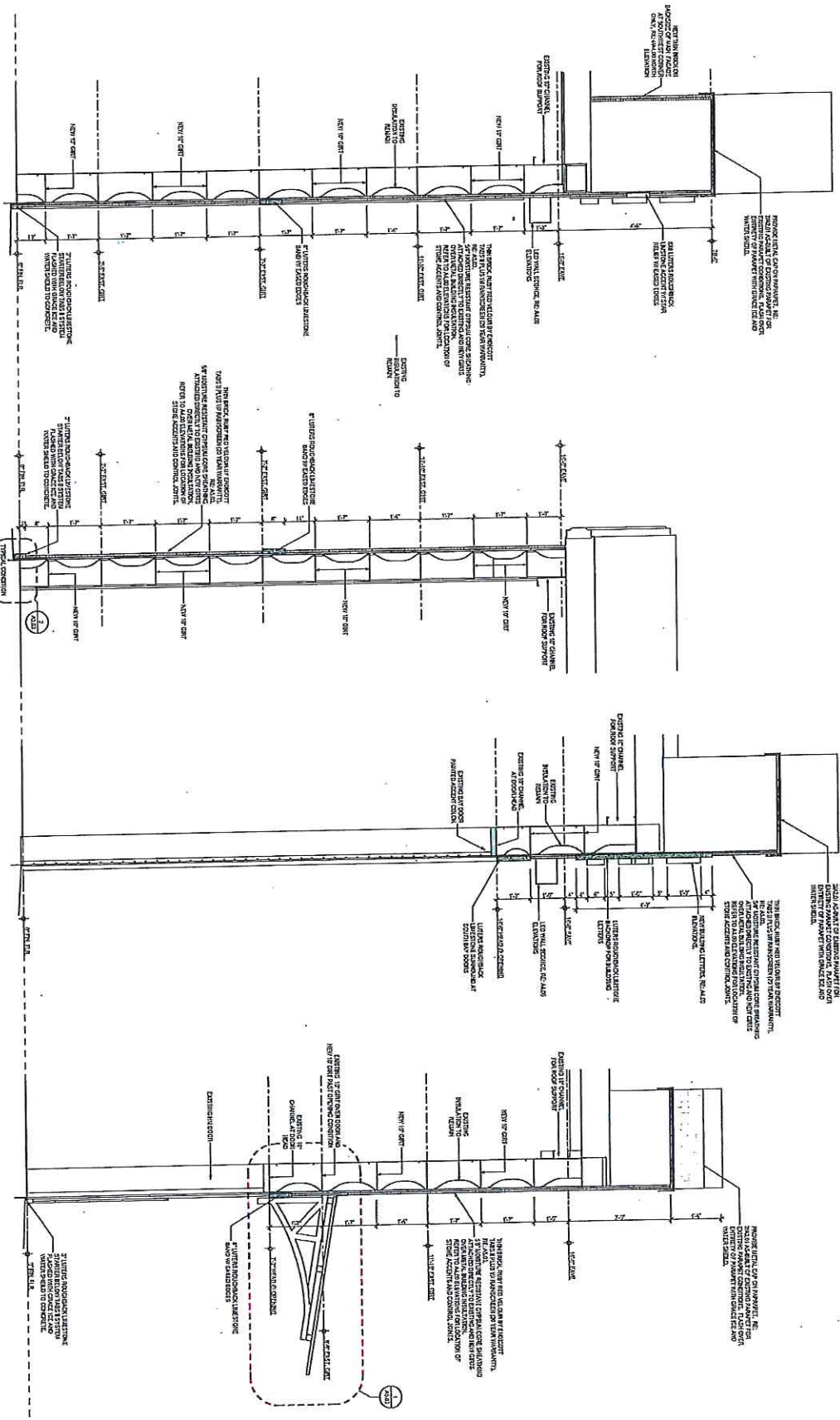

GENERAL NOTES
REFER TO SHEET A41 FOR ARCHITECTURAL GENERAL NOTES, MODIFICATIONS & LAYOUTS, ETC.



FROMBERG ASSOCIATES, LTD
1105 E. South Texas Street, Suite 100
Houston, Texas 77002
Tel: (832) 415-1837 Fax: (832) 415-1837
www.fromberg.com



City of Bastrop
Fire Station Facade Renovation
Bastrop, Texas
Project Number: 1509
Date: 03/02/2016
Scale: A5.01

EXHIBIT C
Color Chart for the Bus Shelter

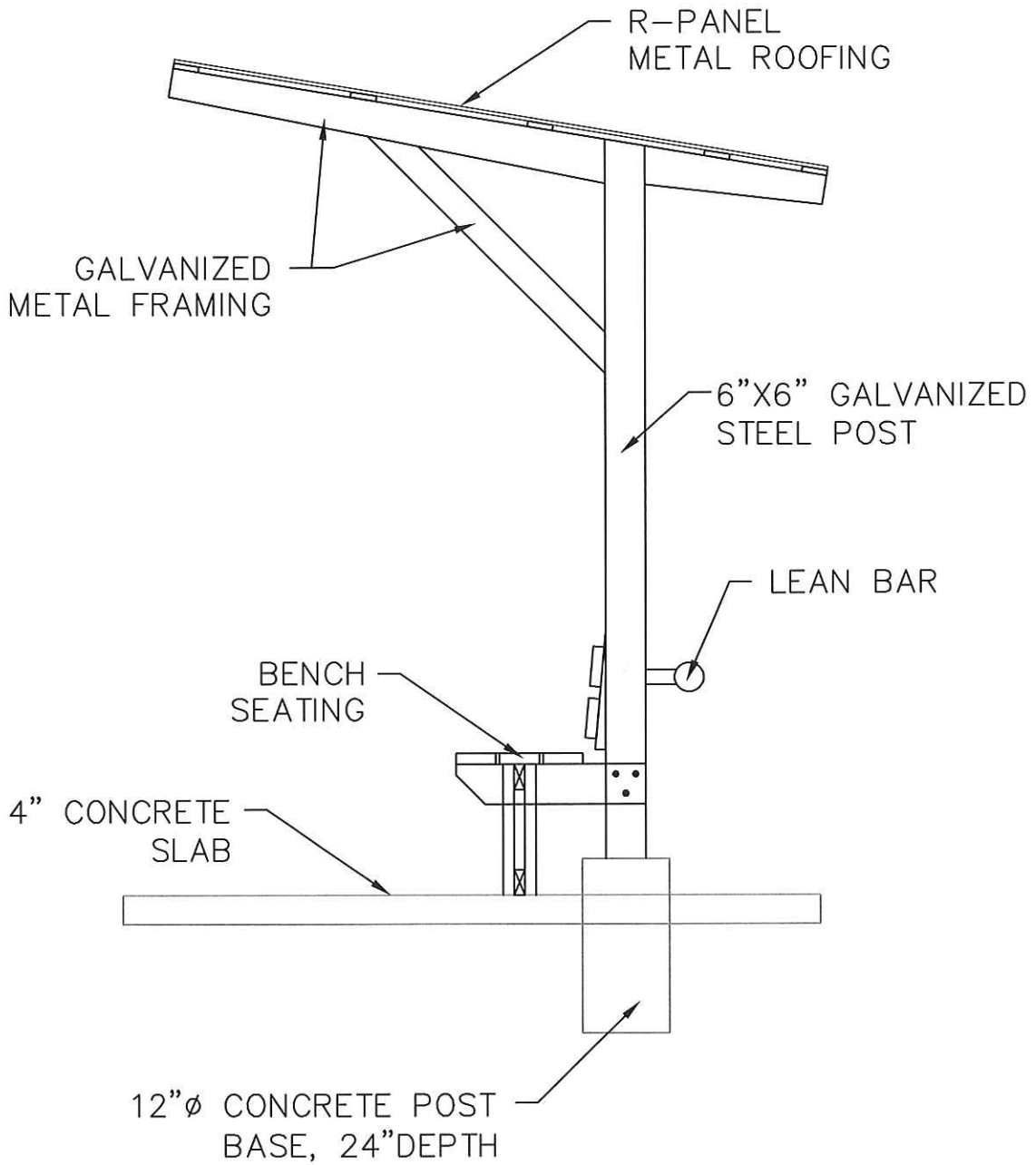

BUS SHELTER SKETCH

CITY OF BASTROP

DATE: AUGUST 15, 2015
SCALE: 1/2"=1'-0"



*Final color selection should be made from actual color chips

STANDARD COLOR OFFERINGS

STANDARD COLOR OFFERINGS

			
POLAR WHITE	LIGHT STONE	ASH GRAY	SADDLE TAN
			
BURNISHED SLATE	RUSTIC RED	EVERGREEN	BERRY
			
COCOA BROWN	CHARCOAL GRAY	CRIMSON RED	HAWAIIAN BLUE
			
BLACK	DESERT SAND	GALLERY BLUE	FERN GREEN
			
IVORY	COPPER METALLIC	GALVALUME	COLONY GREEN

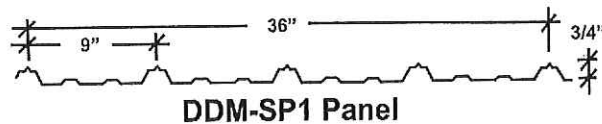
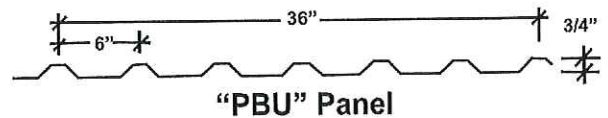
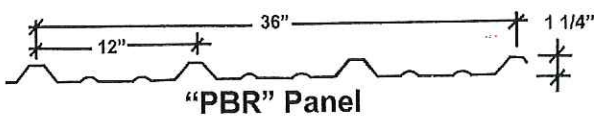

979-251-9503
866-281-DDM1
 301 Salem Road – Brenham

512-321-0336
877-281-DDM1
 1083 Hwy 71 W. – Bastrop

www.ddmpipeandsteel.com

EXHIBIT D
Conceptual Layout for Alley D

EXHIBIT E
Summary of Projects/Programs

SUMMARY OF CURRENT PROJECTS/PROGRAMS FEBRUARY 22, 2015

- The Groundwater Well Permit, pending before the Lost Pines Groundwater Conservation District. The Administrative Hearing, scheduled and pending before the "State Offices of Administrative Hearing – Judge M. O'Malley, is scheduled to begin on March 23 – March 25, 2016. _____
- Development of New Comprehensive Plan for the City of Bastrop. _____
- Amending the 'Bastrop Marketing Corporation' Contract [a/k/a Hyatt Joint Marketing Agreement] _____
- Developing "Deal Points" for a contract between the City of Bastrop and the YMCA of Austin, for a Recreational Facility/Emergency Shelter, including the identification and dedication of land upon which the project will be developed. In the event the City Council determines that this agreement proposed is not feasible, then the "Plan B" that has been previously developed and provided and approved by the Council will need to be implemented. As you recall, Plan B calls for the construction of approximately a 6,000 sq. ft. "Activity Center/Emergency Shelter" to be located at Bob Bryant Park. _____
- Development of cost estimate for the making infrastructure improvements and paving in Alley D. Infrastructure Improvements include: A.) Drainage, B.) Replacement of the wastewater mains and wastewater services, and C.) Installing the electrical lines and electrical services underground. _____
- The Main Street Project: Street and Sidewalk Improvements Project which is primarily being funded by BEDC. If The City Council wishes to expand the sidewalks, adjust the parking and add any additional elements, those alternatives must be decided upon and committed to by the Council within the next couple of months, and funding required for those additional elements, beyond that dedicated by the BEDC, will be the City's responsibility. _____
- Implementation of Bastrop Power & Light Five (5) Year Capital Improvements Program [CIP] as developed by LCRA Electrical Engineering Department. Current projected cost for implementing this five (5) CIP is \$1,000,000.00. _____
- Water & Wastewater Rate & Impact Fee Study: State laws requires that every five (5) years, that the City review, update and revise their water and wastewater Impact Fees and we are in the process of doing this update at this time. The City of Bastrop is looking to make some major water and wastewater infrastructure improvements over the next several years. Though Impact Fees will provide some financial assistance in paying for

Preliminary Summary

these water & wastewater improvements, water and wastewater rates will need to be adjusted to cover the cost of these major infrastructure improvements.

- Creation of a "Public Improvement District" for Phase I of the XS Ranch Project. _____
- The Pine Forrest Unit #6 joint Litigation, with County and BISSD as taxing entities. _____
- Negotiation of a 'Wholesale Wastewater Agreement' for Interim and later service for the West Bastrop Village Municipal Utility District. _____
- Planning for easement acquisition, line routing, design, financing and construction of the West Side Wastewater treatment plant III, on property previously acquired by the City. _____
- Convention Center: Placing a greater emphasis on "Sales & Marketing." This will require an interim approach until the City Council makes a final decision on the Destination Marketing Organization. _____
- Develop and create a structure for the "Destination Marketing Organization." _____
- Gils Branch Lift Station and Wastewater Improvements Project. _____
- Improvement to and operation and marketing of the Rodeo Arena at Mayfest Park. _____
- Developing Strategies with the 'Form Base Code Task Force' for the Redevelopment of the northern area of the City of Bastrop. _____
- Develop a General Obligations Bond Program, to be presented to the Citizens of Bastrop. {Deadline for call for a "Bond Election in November is **August 22, 2016.**}
- Development in conjunction with Bastrop County, of an extension to the "1445 Subdivision Approval Agreement". _____
- Develop a timeline and strategy for the implementation of the major water and wastewater infrastructure construction program. [Elevated Storage Tank on the Westside of the City and related water main improvements] _____
- Development of the FY-17 budget will commence on May 1, 2016. _____

Preliminary Summary

- Implementation of the FY-16 Street Program funded by the "General Fund" and approved City Council. _____

- Undertake evaluation of whether the City is going to continue with the issuance of C.O.'s [\$500,000.00 for water main & system improvements and \$500,000.00 for wastewater mains & system improvements] for FY-16? _____

- Daily Operations and Management in the delivery of "Daily Services". _____

- Continued work to enhance development of the Public Safety Department, with Chief Adcock, including the Bastrop Volunteer Fire Department. Work on equipment acquisition and setting the stage for moving toward paid personnel for the "Fire Department." _____

- Continuing and ongoing working to maintain and develop the professional skills and caliber of the City's employee pool, and encourage the Directors to train and achieve success. Continue to work to fill all critical positions. _____

- Development of Annexation Program for the City of Bastrop. [Comprehensive Plan]. _____

- Quality of Life Issues for the Citizens of Bastrop. _____